

CF-510 PIVOTING DOOR SERIES KIT

INSTRUCTION SHEET
FOR 1-3/4" DOORS UP TO 200LBS PER PANEL

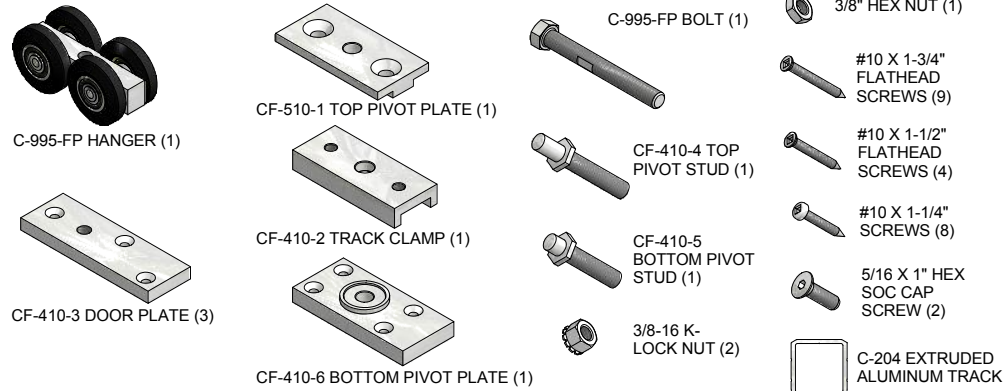

PARTS LIST (FOR 2 DOOR KIT)



DIMENSION DETAILS:

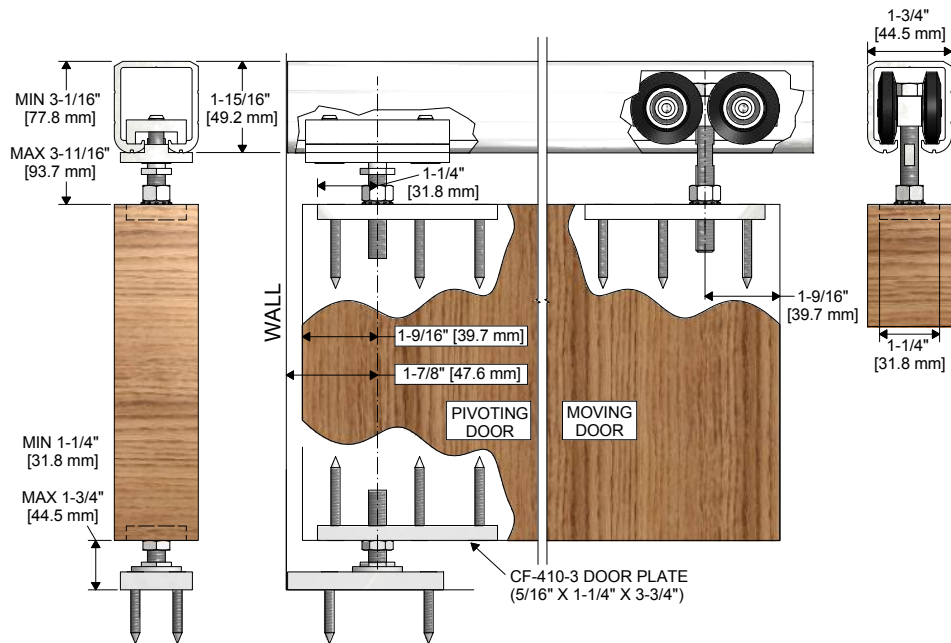

PLAN VIEWS SHOWING CLEARANCE BETWEEN DOORS

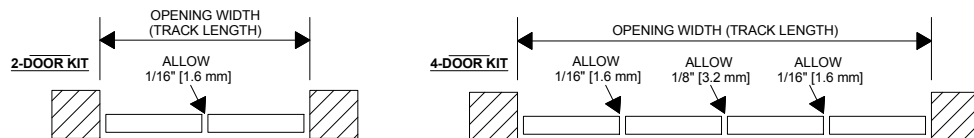

INSTALLATION INSTRUCTIONS

STEP 1

DETERMINE DOOR SIZE/HEADER HEIGHT BASED ON DIMENSIONS SHOWN IN DETAIL VIEWS AND CLEARANCE REQUIRED BELOW DOOR:

- MINIMUM OPENING HEIGHT (A) = DOOR HEIGHT + 4-5/16"
- MAXIMUM OPENING HEIGHT (A) = DOOR HEIGHT + 5-7/16"

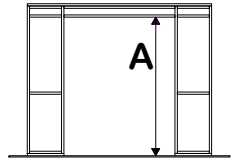

STEP 2

CUT TRACK TO LENGTH & DRILL 13/64"Ø MOUNTING HOLES 10-12" C/C.

TRACK LENGTH SHOULD EQUAL FINISHED OPENING SIZE LESS 1/8".

1) INSERT 5/16" X 1" HEX SOC CAP SCREWS (2) THROUGH CF-510-1 TOP PIVOT PLATE AND THREAD CAP SCREWS INTO CF-410-2 TRACK CLAMP. 2) INSERT ASSEMBLY IN TRACK ON PIVOTING END. 3) INSERT C-995-FP BOLT THROUGH C-995-FP HANGER AND THREAD ONE 3/8-16 K-LOCK NUT WITH WASHER FACING AWAY FROM HANGER. 4) INSERT HANGER ASSEMBLY INTO OPPOSITE END OF TRACK. SECURE TRACK TO HEADER WITH #10 X 1-1/4" SCREWS (8).

STEP 3

PREPARE DOOR FOR CF-410-3 DOOR PLATES. IT IS RECOMMENDED FOR PLATES TO BE FLUSH WITH TOP AND BOTTOM OF DOOR. (DRILL 7/16" CLEARANCE HOLES FOR PIVOT BOLTS) AND SECURE PLATES TO TOP AND BOTTOM OF PIVOTING DOOR, AND TOP OF MOVING DOOR WITH #10 X 1-3/4" SCREWS (3 PER PLATE).

STEP 4

LOCATE AND INSTALL CF-410-6 BOTTOM PIVOT PLATE ON FLOOR WITH #10 X 1-1/2" FLAT HEAD SCREWS (4). FOR 1-3/4" DOORS A MINIMUM OF 1-7/8" FROM WALL TO CENTER OF PIVOT BEARING ON BOTTOM PLATE IS REQUIRED. (SEE DIMENSION DETAILS).

STEP 5

1) THREAD 3/8-16 K-LOCK NUT (1) ONTO CF-410-4 TOP PIVOT STUD AND THREAD INTO TOP DOOR PLATE OF PIVOTING DOOR. 2) THREAD 3/8" HEX NUT ONTO CF-410-5 BOTTOM PIVOT STUD AND THREAD INTO BOTTOM DOOR PLATE OF PIVOTING DOOR. (NOTE: THREAD BOLTS FULLY INTO DOOR PLATES IN ORDER TO PROVIDE ADEQUATE CLEARANCE FOR NEXT STEP).

STEP 6

DOORS SHOULD BE PREASSEMBLED WITH HINGE (BY OTHERS) BY THIS STEP. RAISE DOOR ASSEMBLY INTO PLACE BY POSITIONING CF-410-4 TOP PIVOT BOLT INTO CF-510-1 TOP PIVOT PLATE. GUIDE CF-410-5 BOTTOM PIVOT BOLT INTO CF-410-6 BOTTOM PIVOT PLATE BEARING.

STEP 7

CAREFULLY SWING MOVING DOOR INTO POSITION AND ENGAGE C-995-FP BOLT (STEP 2) INTO CF-410-3 DOOR PLATE. ADJUST BOLT WITH 5/16" WRENCH. SECURE SETTING WITH LOCK NUT. ALTHOUGH HANGER C-995-FP IS RATED FOR OVER 150LBS, MAJORITY OF LOAD SHOULD BE CARRIED BY THE BOTTOM PIVOT ASSEMBLY FOR SMOOTH OPERATION.

STEP 8

ADJUST CF-410-4 TOP PIVOT BOLT UPWARDS USING A 5/8" WRENCH TO RE-ENGAGE CF-510-1 TOP PIVOT PLATE AND LOCK TRACK PIVOT PLATE ASSEMBLY USING 3/16" HEX KEY.

STEP 9

IF PIVOTING OF DOOR RESULTS IN BOTTOM PIVOT BOLT LIFTING OFF OF CF-410-6 BOTTOM PIVOT PLATE THIS INDICATES THAT THE PIVOTING PLANE IS NOT PERPENDICULAR TO THE TRACK. ADJUST PLUMB AS REQUIRED BY REPOSITIONING TRACK PIVOT PLATE ASSEMBLY. ONCE ADJUSTMENTS ARE FINAL, LOCK IN PLACE WITH 3/8-16 K-LOCK NUTS.

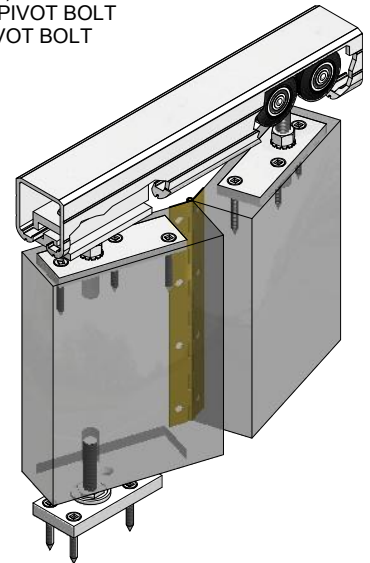
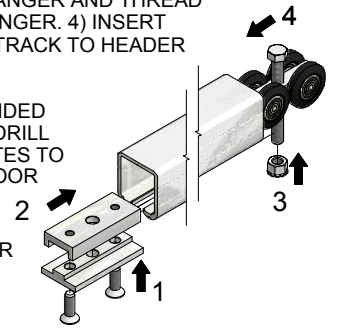

K.N. CROWDER MFG. INC.
1220 BURLOAK DRIVE
BURLINGTON, ONTARIO, CANADA, L7L 6B3
TELEPHONE: 905-315-9788 - FAX: 905-315-8090
TOLL FREE FAX: 1-800-567-0123

K.N. CROWDER INC.
210 EIGHTH STREET SOUTH
LEWISTON, NEW YORK, U.S.A. 14092
TELEPHONE: 1-716-754-8247
TOLL FREE FAX: 1-800-567-0123

WEBSITE: www.kncrowder.com -- E-MAIL: customerservice@kncrowder.com